

Class 150LB 1/2"~4"

Technical Specification:
 1.Design Spec:ISO-17292
 2.Pressure Temp:ASME B16.34
 3.Face to Face:ASME B16.10
 4.End connection:ASME B16.5
 5.Test Check:API-598
 6.Shell Material:ASTM A351

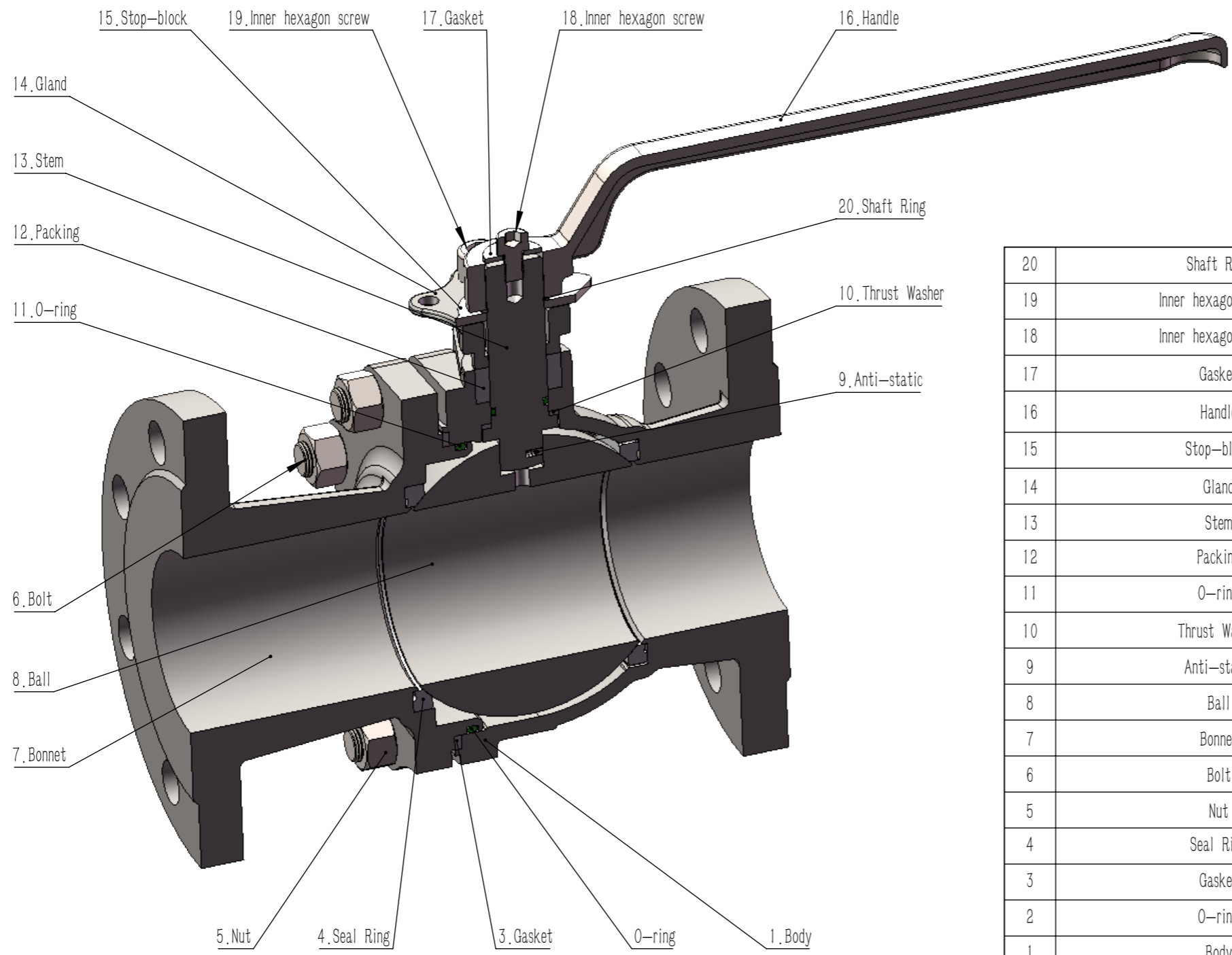

No.	Name	Material	Notes
20	Shaft Ring	SS	
19	Inner hexagon screw	A193 B8	
18	Inner hexagon screw	A193 B8	
17	Gasket	SS	
16	Handle	A351 CF8	
15	Stop-block	SS	
14	Gland	A351 CF8	
13	Stem	A276 304	
12	Packing	Graphite	
11	O-ring	Viton	
10	Thrust Washer	PTFE	
9	Anti-static	SS	
8	Ball	SS304	
7	Bonnet	A351 CF8	
6	Bolt	A193 B8	
5	Nut	A194 8	
4	Seal Ring	PTFE	
3	Gasket	SS304+Graphite	
2	O-ring	Viton	
1	Body	A351 CF8	

Parts code

tracing

draft and check

sign

date

						ASTM A351 CF8			Jiangsu Unicents Valve Co., Ltd.	
sign	revise	reversion	signature	sign	date	pattern marking	weight	proportion	Gate Valve	
design	standardization									
check									Class 150LB 1/2"~4"	
technology					date	total Page	The first page			